

PRIME Cleanout

Part of the PRIME digital electro-hydraulic intervention technology platform.

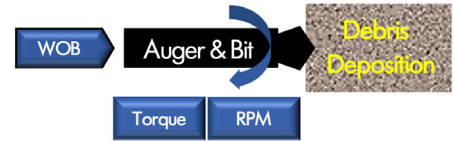

Critical to optimizing rotational based wellbore cleanout operations is the ability to provide the required parameters of torque, weight on bit (WOB) and RPM combined with a specifically designed bit and augur system, in turn delivering optimized rate of penetration (ROP) throughout the task at hand.



Also critical is the ability to monitor, control and adjust these parameters throughout the rotational based debris dislodge and debris collection exercise, to handle the often confronted variations in debris material type (e.g. solids, viscous slurries, junk) and deposition (e.g. partial or full bore, compacted or loose). With debris often accumulating in highly deviated sections of a wellbore, such parameter control is also required in this circumstance.

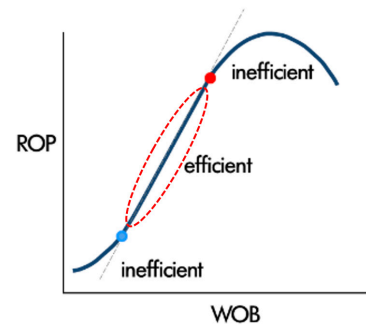

The PRIME Direct Drive Rotation (DDR) is a highly instrumented, high torque rotational device with realtime in-well monitoring, control, and adjustment capability.

	PRIME DDR 212	PRIME DDR 318
Tool body OD	2.5 in (63.5 mm)	3.307 in (84.00 mm)
Length	7.78 ft (2.37 m)	7.64 ft (2.33 m)
Pressure rating	15,000 psi (1,034 bar)	
Temperature rating	177 °C (350 °F)	

Built on a common tool architecture, the PRIME DDR is seamlessly integrated with the **PowerTrac**® PRIME Tractor which, in addition to providing efficient conveyance of the cleanout toolstring to task depth, also provides the required rotational anchor and the controlled WOB for bit advancement into the debris column in deviated wells.

SPEC SHEET

Further efficiency gains come from active stall control recovery which vastly improves effective debris dislodge of collection time. On-the-fly switching capability of the rotational anchor between free-wheeling (rolling) or tractor driven mode enables uninterrupted back reaming capability. This is crucial when effectively "drilling" into a debris column while simultaneously accumulating the debris in collection chambers for removal from the wellbore.

Free-rolling Anchor



All Drive Section arms extended; wheels disengaged
– to provide rotational anchor for Milling service support

Driven Anchor



All Drive Section Arms extended; only lower wheels engaged
– to provide rotational anchor with driving force for Milling WOB

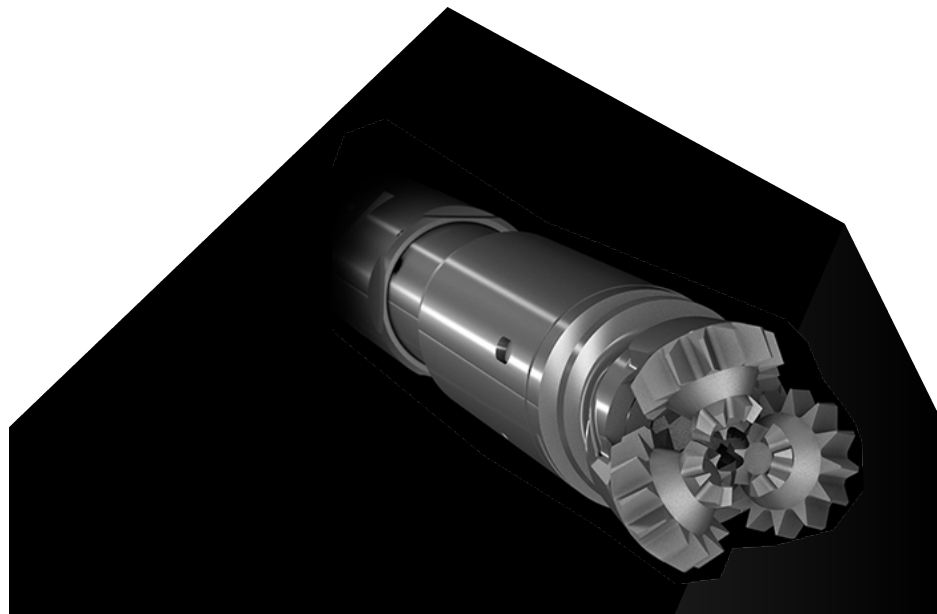

SPEC SHEET

The **PrecisionCollector** is a robust, full system cleanout technology that can remove a wide range of debris types in varying well conditions. It mills, agitates and dislodges the debris downhole, collecting and retaining it in debris chambers for transportation out of hole. It is run in combination with **PowerTrac**® for anchoring and providing weight on bit, coupled with a Direct Drive Rotation (DDR) device to generate the required rotational force.

Applications

- Removal and collection of a wide range of wellbore debris:
- Unconsolidated (e.g. proppants, sand)
- Consolidated (settled barites, hard scale)
- Vicious (asphaltenes, waxes)
- Wells where circulation for cleanout is not recommended or not possible

Features

- Robust mechanical collection mechanism, not requiring fluid circulation
- Mechanical interaction and friction separates debris from fluid, rather than filtration
- Highest solids recovery content per collected volume of debris
- Customisable bottom hole assembly (BHA) with operational flexibility depending on debris in well
- Real-time monitoring of key milling parameters; weight on bit (WOB), bit speed, vibration

Benefits

- Provides loosening, collection and recovery of debris to surface in one run
- Best technology option if debris composition and consistency is unknown or varying
- Operates in wet and dry environments
- Precise, cost effective and low risk wellbore cleanout service
- Light on logistics, footprint, personnel and time

	PrecisionCollector 250	PrecisionCollector 350	PrecisionCollector 380	PrecisionCollector 450
Tool body OD	2.50 in (63.5 mm)	3.50 in (88.9 mm)	3.8 in (96.5 mm)	4.5 in (114.3 mm)
Typical bit types used	PrecisionRock Bit			
Recommended minimum bit size OD	≥ 2.625 in	≥ 3.625 in	≥ 3.925 in	≥ 4.625 in
Capacity per reservoir chamber OD	2.36 litres (0.62 gallons)	5.16 litres (1.36 gallons)	5.8 litres (1.53 gallons)	9.4 litres (2.48 gallons)
Makeup length single reservoir chamber	3.6 ft (1.10m)	3.9 ft (1.19m)	3.9 ft (1.19m)	3.9 ft (1.19m)
"Standard" configuration capacity^{2,4}	11.8 litres (3.12 gallons)	25.8 litres (6.82 gallons)	29.0 litres (7.66 gallons)	47.0 litres (12.42 gallons)
"Standard" configuration total makeup length^{2,5}	19.4 ft (5.91 m)	21.8 ft (6.65 m)	21.8 ft (6.65 m)	21.8 ft (6.64 m)
System pressure rating	15,000 psi (1,034bar)			
System temperature rating	177 °C (350 °F)			
Deviations	Vertical to horizontal			

1. Tool OD only (not bit OD).

2. Standard configuration for **PrecisionCollector** is 5 reservoir chambers but may be increased dependent on rig up height.

3. Standard output. Customisable down gearing possible with a 3:1 gear.

4. Excludes volume in bottom connector for all sizes and top section for 350,380 and 450

5. Length includes reservoir chambers. Does not include length of RockBit, Direct Drive Rotation, **PowerTrac**® and accessories.

SPEC SHEET

An additional capability offered by PRIME platform's instrumentation communication bus embedded within the toolstring infrastructure is the addition of a connected fill indicator device. Integrated into the fluid exit sub of the top debris collection chamber, this device provides a clear and immediate real-time indication of when the collection chamber string is full of debris. This elevates the operational certainty and efficiency gains to the PrecisionCollector's debris collection process, eliminating unnecessary collection time and pulling out of hole with a partially full chamber string. In addition to the obvious time savings, this feature minimizes the well exposure time of the debris collection phase, and in doing so considerably reduces the risk of the collection string getting stuck in the well.

The **PowerTrac**® PRIME Tractor and PRIME DDR's advanced real-time controls and feedback take wellbore cleanout into a new performance envelope. The rotational torque and RPM of the DDR as well as tractor force and speed can be monitored and controlled simultaneously, in real-time, allowing parameter adjustments according to encountered conditions. As an example, when drilling into heavy debris and increased torque is observed the rpm can be reduced along with feathering of the WOB. If cleaning through debris bridges the rotational torque limit may be lowered while full rpm is maintained. Once clear, tractor speed can be increased to perform a rapid scraper pass till the next ledge of debris is confronted. This allows fast forward movement without accidentally forcing the bit into new debris in the well trajectory. Active stall control and seamless back-reaming capability allow easy wiper tripping while always maintaining rotation of the tools exposed front end – the bit and auger.

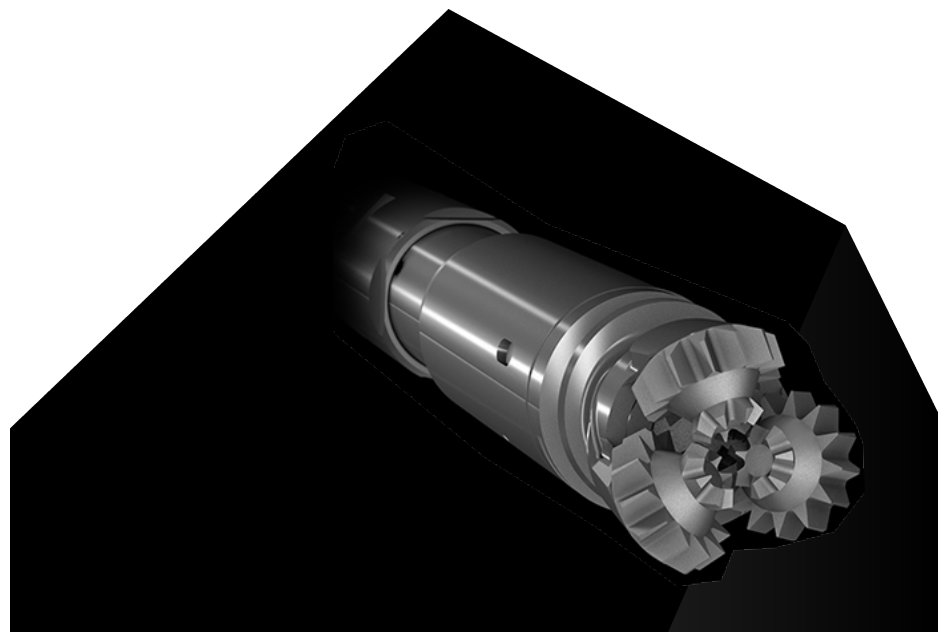

PRIME

SPEC SHEET

PRIME Release Sub System – The Release Sub System (RSS) has been developed to enable controlled release of stuck toolstrings. Multiple RSS's can be utilized, placed at the top of the toolstring or at relevant positions along its length enabling partial retrieval. The PRIME RSS has integrated PRIME node electronics, enabling full PRIME communication and in-well functionality to PRIME tools positioned below, and in-hole configurability for release parameters. It also provides realtime release status based on sensor reading and battery life measurement.

RSS release is activated by telemetry commands, voltage variation or memory timer mode, enabling controlled release even with damaged cable.

Applications

- Logging toolstrings in cased and open hole
- Tractor conveyance and Powered Mechanical Applications

Features

- Release energized through wireline or battery
- Extended battery life
- High torque design enabling usage with milling applications
- Real time in-well configuration to adapt for changes in work scope

Benefits

- Can release even if cable is damaged
- QHSE; reduces personnel exposure to cable breakage at surface due to high overpull
- Improved operational efficiency; less runs, increased measurements per run
- More efficient retrieval/fishing due to clean fishing neck after release

	RSS 218	PRIME RSS 212	RSS 318
Tool body OD	2.125 in (54.00 mm)	2.5 in (63.50 mm)	3.125 in (79.38 mm)
Length	3.41 ft (1.04 m)	3.63 ft (1.10 m)	3.9 ft (1.19 m)
Min restriction ID	2.5 in (63.50 mm)	2.625 in (66.68 mm)	3.25 in (82.55 mm)
Pressure rating	15,000 psi (1,034 bar)		
Temperature rating	177 °C (350 °F)		
Fishing neck	1.38 in (35.1 mm)	1.75 in (44.5 mm)	1.75 in (44.5 mm)