

# CASE STUDY

**Country:** UK

**Year:** 2022

**Technologies:**

- PRIME Tractor 212
- PRIME Direct Drive Rotation 318
- Brush
- Explosive Expansion Tool

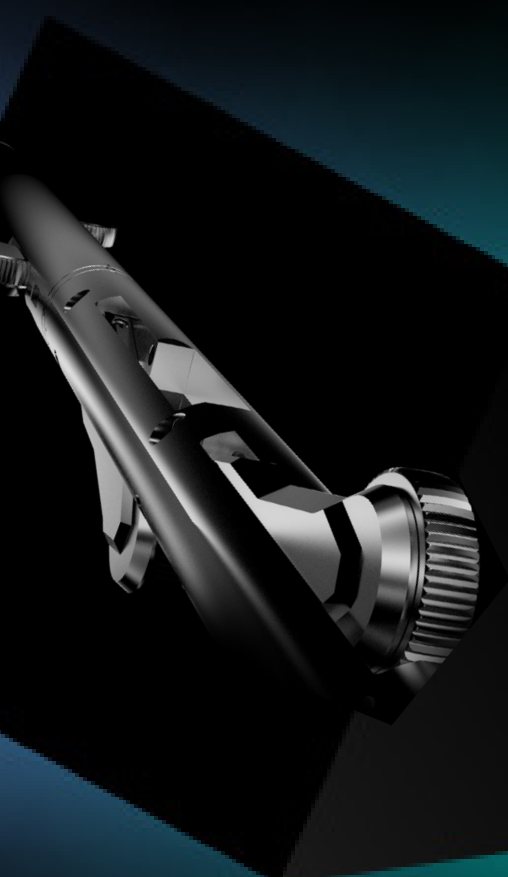

## Cleanout coupled with explosive tubing expansion technology used successfully in North Sea

- World first expansion of 5 in. 23 lb/ft. tubing using the W.T. Bell expansion charge
- Extensive design, planning and testing done to optimise the charge design
- Use of e-line deployed brush for plastic coating removal in tubing

### Challenge

A North Sea Operator required a well intervention to be designed and executed to prepare a well for plug and abandonment operations. The plan was to set metallurgically bonded alloy barriers just below the liner lap. This was to be achieved by placing and retaining alloy material at the target depth and thermally activating to establish requisite abandonment barriers. Plastic coated-tubing was used in the well to prevent corrosion over the well's life. This meant a section of the coating would first need to be removed at the target depth. This would enable the internally placed alloy plug to be in direct contact with the tubing wall, in turn enabling the barrier assurance when thermally activated. In addition, the 5 in. tubing had to be expanded at the target depth to bring it in close proximity to the ID of the 7 in. liner. This would create an annular ledge on which the alloy material would collect when deployed into the annulus, prior to being activated to establish the annular barrier.

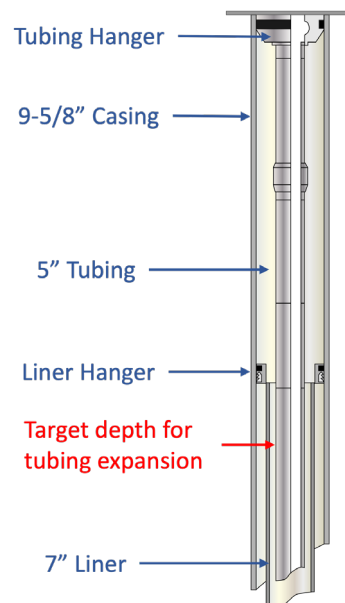

### Solution

An e-line solution was devised, consisting of two key steps:

- Firstly, following a drift run with pressure/temperature sensor, an e-line deployed and powered electro-hydraulic rotational system with a suitable cleaning head would be run in hole and activated across the target zone to remove approximately 35 ft. of the plastic lining. Specifically, the Altus Intervention **PowerTrac®** PRIME Tractor combined with the PRIME Direct Drive Rotation and brush was recommended. The PRIME technology provided a high degree of sensors and instrumentation, with real-time visibility and control throughout the cleanout operation.

Several plastic liner removal tool designs were built and tested at the Altus Intervention facility in Aberdeen. Designs included the use of a hone, blades and wire, and were tested at ambient and at temperature before selecting the most effective one for the specific well completion – a 10 hole brush built using stiff wire.

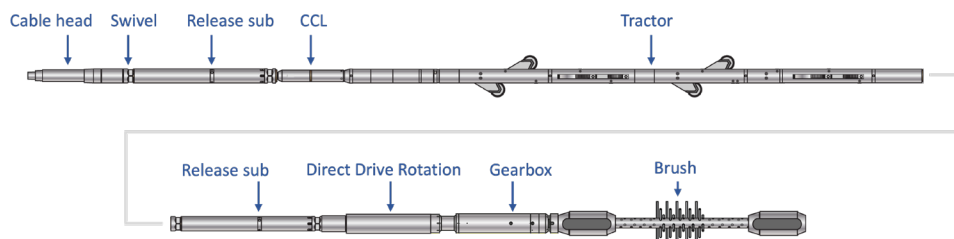

**Tubing cleaning toolstring**

- Secondly, an explosive expansion charge would be run to target depth and activated. The aim was to expand the 5 in. tubing OD to 6.034 in., close to that of the 7 in. liner ID. The charge size was selected to ensure sufficient tubing expansion to create the ledge in the annulus, but without risk of damage (splitting) to the tubing hence maintaining its integrity. The W.T. Bell International expansion charge was chosen as the preferred solution. This was custom manufactured and tested extensively at their facility in Texas, taking into consideration the tubing size and specification (weight & grade), the wellbore fluid type and anticipated hydrostatic pressure, and the 26 degree well deviation at target depth. Six tests were completed in a pressurised test chamber to confirm the control and the capability of expanding the tubing to the prerequisite OD. The thorough testing confirmed the tubing could be expanded to the required OD without rupture.



**Example of test pipes expanded using various charge sizes**

The deployment toolstring was configured with centralisers to ensure appropriate positioning of the expansion charge in the well. Finally, a multi-finger caliper log (MIT) would be run after the expansion was completed to confirm the resulting tubing ID and that no rupture had occurred.

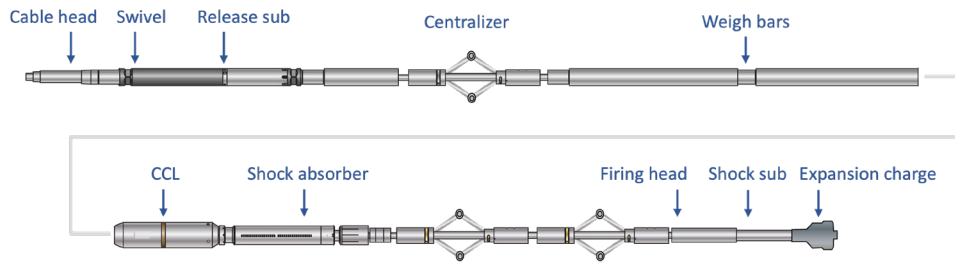

Expansion charge toolstring

## Results

All runs were carried out as per the programme design. The plastic lining was successfully removed by the brush. This was validated by the log showing the difference in current draw between 1st and 2nd pass of the brush.

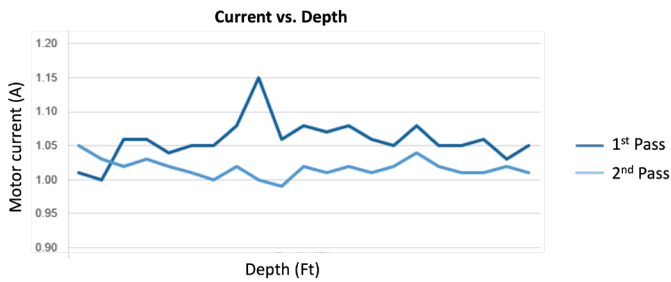

Motor current observed during job execution

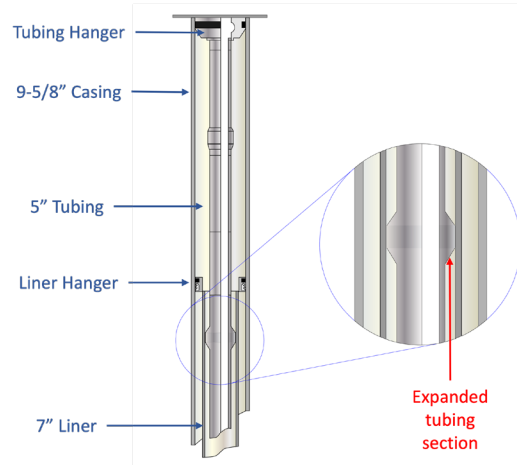

The tubing expansion was achieved with no rupture as confirmed by the multi-finger caliper log. This was a world first expansion of 5 in. tubing using the W.T. Bell charge, providing an innovative solution for controlled tubing expansion.

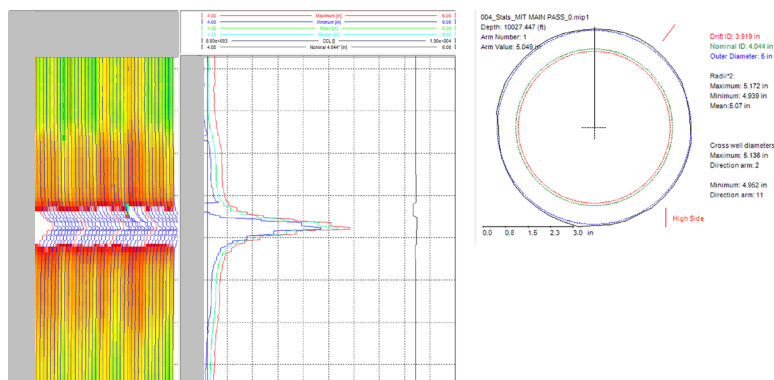

Multi-finger Caliper log data showing the resulting ID of the 5 in. tubing after expansion